

MINIOVAL-1X



2,5-8 cm

3D letters, lightboxes



- luminous efficacy 114 lm/W
- for indoor and outdoor use
- 100 pcs in chain
- ideal for creating a "halo" effect

DIMENSIONS

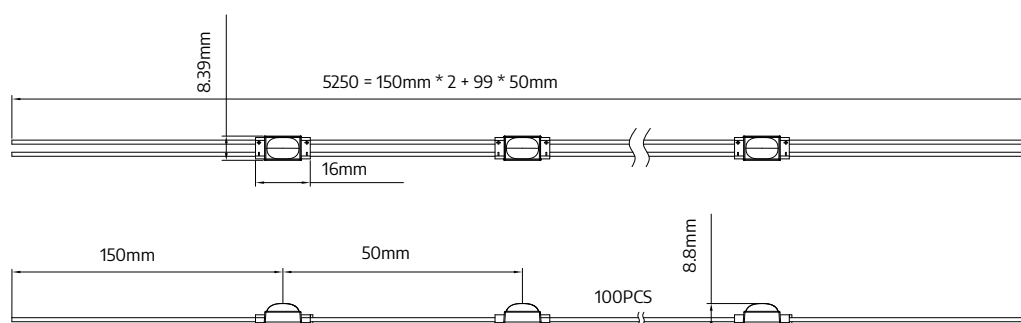

MINIOVAL-1X



TECHNICAL SPECIFICATION

Parameter	Value
Rated voltage	12 V DC
Power consumption per module	0,36 W
Chain power consumption	36 W
Current consumption per module	30 mA
LED diodes	EPISTAR - 2835
Quantity of LEDs	1
Light color	X = W - white (6500K) X = WW - warm white (3000K)
Flux	41 lm
Flux density	114 lm/W
Color rendering index CRI	≥70 (on request ≥80, ≥90, ≥95)
Beam angle	170 x 130°
Current stabilization	No
Dimming	Yes
Module dimensions (L × W × H)	16 × 9 × 9 mm
Cable length	34 mm
Number of modules in 1 m	20
Box weight	14 kg
Montage	Adhesive tape / mounting screw
Lifetime	L70B50 > 50000h
Working temperature	-25°C ... +55°C
IP protection	IP67
Warranty	5 years

MINIOVAL-1X



CONNECTION DIAGRAM

One-side power input



Maximum number of modules 100 pcs

Two-side power input



Maximum number of modules 200 pcs

It is acceptable to connect multiple chains in parallel, as long as the power supply provides sufficient power.

BEAM ANGLE

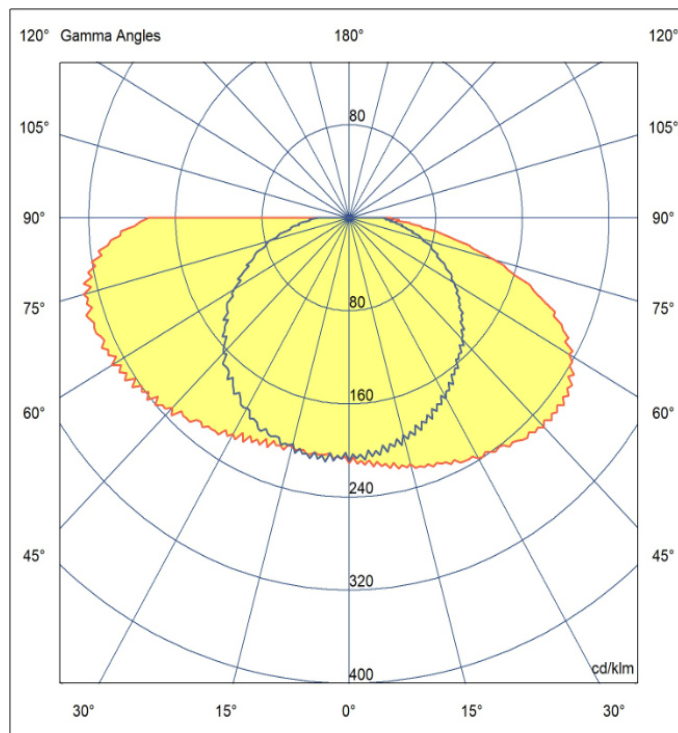

LIGHT COLOR / CCT

Abbreviation	Light color	CCT
WW	warm white	~3000K
NW	neutral white	~4000K
W	white	~6500K
CW	cold white	~10000K

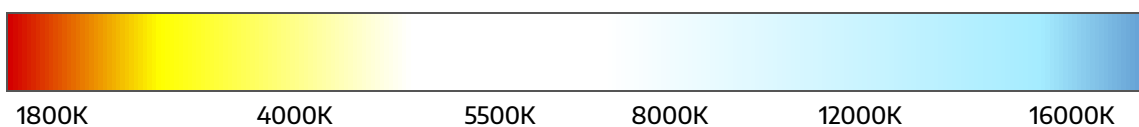

MINIOVAL-1X



PACKING

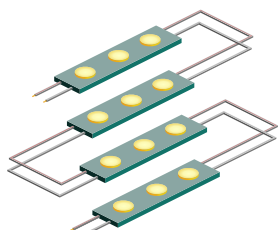

Chain
100 pcs



Bag
100 pcs

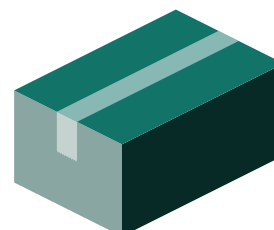

Box
6000 pcs

OTHER NOTES

The 3M tape placed on the device is only used to pre-attach and position the LED modules. Use your own glue or mounting screw to securely and permanently attach the item to the surface.